

40M

JXRZ 40-5.16



GENERAL

PIPE SIZE (ID)	125 mm (5")
BOOM CONTROL VALVE	Proportional (by HAWE)
RADIO REMOTE	Dual Wireless Transmitter System
VIBRATOR	Standard
WATER PUMP	Hydraulic Power 20 bar (290 psi)
WATER TANK	800 L (211 G)
WEAR PARTS	Carbide
POPULAR UPGRADES [†]	<ul style="list-style-type: none"> • LED Boom Light Kit • LED Outrigger Lights • Heated Water Tank • Heated Hydraulic Tank • Air-Cuff • Twin Wall Pipe • 20 cell Pump Kit • 18 cell Pump Kit

BOOM

NUMBER OF BOOMS	5 Sections
FOLDING TYPE	RZ Fold
VERTICAL HEIGHT	39.2m (128'7")
HORIZONTAL REACH	35.2m (111'8")
UNFOLDING HEIGHT	8.2m (26'10")
1ST SECTION	7.9m (25'11")
2ND SECTION	6.6m (21'8")
3RD SECTION	6.3m (20'8")
4TH SECTION	7.0m (22'9")
5TH SECTION	7.4m (24'3")
OUTRIGGER	X-Style
FRONT SPREAD	7.0m (23')
REAR SPREAD	7.6m (24'11")

[†]More options available, ask your sales rep for details.

PUMP

OUTPUT:	Rod Side	164 m³/h (215 yd³/h)
	Piston Side	102 m³/h (133 yd³/h)
PRESSURE:	Rod Side	72 Bar (1044 psi)
	Piston Side	115[‡] bar (1668 psi)
CONCRETE CYLINDER DIAMETER	230 mm (9")	
CONCRETE CYLINDER TYPE	Hard Chromed	
STROKE LENGTH	2100 mm (83")	
S-TUBE SIZE	9" x 7"	
MAIN OIL PUMP	Rexroth hydromatic A11VLO260	
HYDRAULIC SYSTEM PRESSURE	350 bar (5076 psi)	
LUBE SYSTEM (HOPPER)	Automatic	
SWITCHING SYSTEM	Hydraulic	
HOPPER CAPACITY	Easy Clean 600 L (158 G)	
NUMBER OF STROKES/MIN	31	
OUTPUT CONTROL RANGE	10(13)-164m³/h (215yd³/h)	

[‡]Not to be used through boom pipe

Alliance Concrete Pumps Inc. reserves the right to make changes to all specifications

ALLIANCECONCRETEPUMPS.COM



USA OFFICE: 800 West Ridge Road, Linwood, PA 19061
Toll Free 1.888.584.7231 | Phone 610.584.7231 | Fax 610.584.7251

CANADA OFFICE: 26162 30A Avenue, Aldergrove, BC V4W 2W5
Toll Free 1.888.870.0908 | Phone 604.607.0908 | Fax 604.607.0903

40M WEIGHTS/DIMENSIONS



CHASSIS

MAKE/MODEL	FRONT AXLE	REAR AXLE	OVERALL LENGTH	TOTAL WEIGHT
LARGE CONVENTIONAL	18,300 lbs	42,500 lbs	39'6" / 12.0m	60,800 lbs
CAB OVER	19,600 lbs	41,050 lbs	36'10" / 11.2m	60,650 lbs

DIAGRAMS

OUTRIGGER EXTENSION

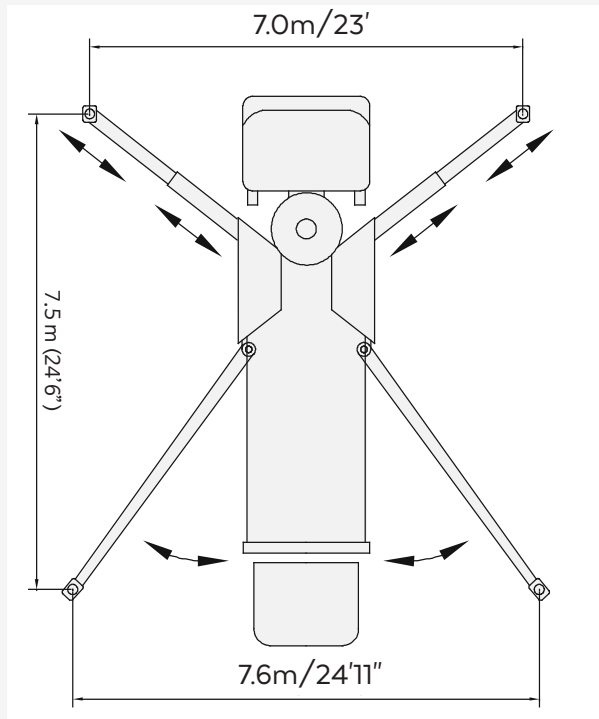

BOOM PUMP REACH

