

38M

JXLR 38-4.16



GENERAL

| | |
|--------------------|--|
| PIPE SIZE (ID) | 125 mm (5") |
| BOOM CONTROL VALVE | Proportional (by HAWE) |
| RADIO REMOTE | Dual Wireless Transmitter System |
| VIBRATOR | Standard |
| WATER PUMP | Hydraulic Power 20 bar (290 psi) |
| WATER TANK | 800 L (211 G) |
| WEAR PARTS | Carbide |
| POPULAR UPGRADES† | <ul style="list-style-type: none"> • LED Boom Light Kit • LED Outrigger Lights • Heated Water Tank • Heated Hydraulic Tank • Air-Cuff • Twin Wall Pipe • 20 Cell Pump Kit • 18 Cell Pump Kit |

BOOM

| | |
|------------------|------------------------|
| NUMBER OF BOOMS | 4 Sections |
| FOLDING TYPE | R Fold |
| VERTICAL HEIGHT | 37.1 m (121'9") |
| HORIZONTAL REACH | 33.1 m (108'7") |
| UNFOLDING HEIGHT | 8.6 m (28'3") |
| 1ST SECTION | 8.7 m (28'7") |
| 2ND SECTION | 7.89 m (25'11") |
| 3RD SECTION | 8.08 m (26'6") |
| 4TH SECTION | 8.43 m (27'8") |
| OUTRIGGER | X-Style |
| FRONT SPREAD | 6.3 m (20'8") |
| READ SPREAD | 7 m (23') |

†More options available, ask your sales rep for details.

PUMP

| | | |
|----------------------------|--|---|
| OUTPUT: | Rod Side | 164 m³/h (215 yd³/h) |
| | Piston Side | 102 m³/h (133 yd³/h) |
| PRESSURE: | Rod Side | 72 Bar (1044 psi) |
| | Piston Side | 115[‡] bar (1668 psi) |
| CONCRETE CYLINDER DIAMETER | 230 mm (9") | |
| CONCRETE CYLINDER TYPE | Hard Chromed | |
| STROKE LENGTH | 2100 mm (83") | |
| S-TUBE SIZE | 9" x 7" | |
| MAIN OIL PUMP | Rexroth hydromatic A11VLO260 | |
| HYDRAULIC SYSTEM PRESSURE | 350 bar (5076 psi) | |
| LUBE SYSTEM (HOPPER) | Automatic | |
| SWITCHING SYSTEM | Hydraulic | |
| HOPPER CAPACITY | Easy Clean 600 L (158 G) | |
| NUMBER OF STROKES/MIN | 31 | |
| OUTPUT CONTROL RANGE | 10(13)-164m³/h (215yd³/h) | |

‡Not to be used through boom pipe

Alliance Concrete Pumps Inc. reserves the right to make changes to all specifications

ALLIANCECONCRETEPUMPS.COM



USA OFFICE: 800 West Ridge Road, Linwood, PA 19061

Toll Free 1.888.584.7231 | Phone 610.584.7231 | Fax 610.584.7251

CANADA OFFICE: 26162 30A Avenue, Aldergrove, BC V4W 2W5

Toll Free 1.888.870.0908 | Phone 604.607.0908 | Fax 604.607.0903

38M WEIGHTS/DIMENSIONS



CHASSIS

| MAKE/MODEL | FRONT AXLE | REAR AXLE | OVERALL LENGTH | TOTAL WEIGHT |
|---------------------------|------------|------------|----------------|--------------|
| SMALL CONVENTIONAL | 16,800 lbs | 38,900 lbs | 40'6" / 12.3m | 55,700 lbs |
| LARGE CONVENTIONAL | 18,150 lbs | 39,450 lbs | 41'5" / 12.6m | 57,600 lbs |
| CAB OVER | 19,900 lbs | 37,350 lbs | 38'5" / 11.7m | 57,250 lbs |

DIAGRAMS

OUTRIGGER EXTENSION

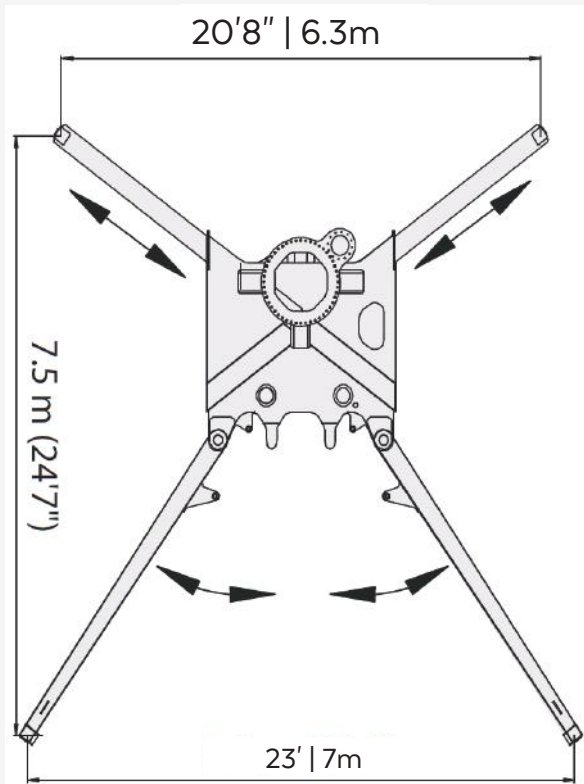

BOOM PUMP REACH

